



Engine	Kubota D1703
Rated Power	25.7 kW (35 hp / 35 ps) @2,800 rpm
Nominal Amplitude Range	0.45 mm
Vibration Frequency Range	55 / 65 Hz
Centrifugal Force Range	35 / 40 kN
Working Width	1,200 mm
Operating Weight	2,700 kg

6027F ROLLER

6027F SPECIFICATIONS >>>

ENGINE

Emission Regulation	Tier 3
Manufacturer	Kubota
Model	D1703
Rated Power	25.7 kW (35 hp / 35 ps) @2,800 rpm
Peak Torque	113 N·m
Number of Cylinders	3
Aspiration	Turbo
Cooling Type	Water
Displacement	1.647 L

ELECTRICAL SYSTEM

System Voltage	12 V / 60 A
Battery	12 V / 72 Ah

DRIVE TRAIN

Theoretical Gradeability	30%
Operating Speed, Fwd	0-10 km/h
Min. Outside Turning Radius	2,760 mm

PERFORMANCE

Front Drum Static Linear Load	11.2 N/cm
Rear Drum Static Linear Load	11.2 N/cm
Number of Vibrating Drums	2
Nominal Amplitude	0.45 mm
Vibration Frequency	55/65 Hz
Centrifugal Force	35/40 kN
Drum Diameter	720 mm
Drum Width	1,200 mm
Drum Thickness	11 mm

OPERATING WEIGHT

Operating Weight	2,700 kg
Weight on Front Drum	1,350 kg
Weight on Rear Drum	1,350 kg

SERVICE CAPACITIES

Fuel Tank	45 L
Engine Oil	7 L
Hydraulic Oil Tank	43 L
Cooling System	3 L
Vibrating Housing	5.5×1 L
Water Tank	180 L

DIMENSIONS

A Overall Length	2,535 mm
B Overall Width	1,300 mm
C Compaction Width	1,200 mm
D Wheelbase	1,760 mm
E Steering Angle	±32°
G Min. Ground Clearance	255 mm
H Overall Height	2,860 mm
Swing Angle	7±1°

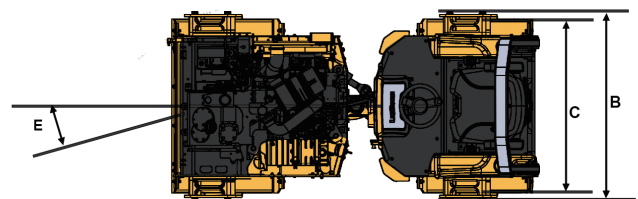
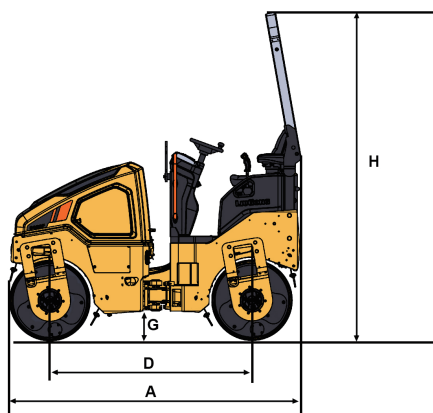

Guangxi Liugong Machinery Co., Ltd.

No. 1 Liutai Road, Liuzhou, Guangxi 545007, PR China
T: +86 772 3886124 E: overseas@liugong.com
www.liugong.com

10/202 Designed by LiuGong

Specifications and designs are subject to change without notice. Machines shown may include optional equipment. LiuGong standard and optional equipment may vary from region to region. Please consult your LiuGong dealer for information specific to your area. Engine power kW is converted to horsepower (1 kW=1.3596 ps and 1 kW=1.3410 hp) in this file.