



8110TE

BATTERY TYPE	LFP
RATED STORAGE ENERGY	706 kWh
OPERATING WEIGHT	41,000kg
STANDARD BUCKET SIZE	6.2 m ³
STANDARD BREAKOUT FORCE	317 kN
STANDARD DUMP CLEARANCE	3,350 mm



B A T T E R Y E L E C T R I C V E H I C L E

TOUGH WORLD. TOUGH EQUIPMENT.

8110TE

SPECIFICATIONS >>>

POWER BATTERY	
Battery Type	LFP
Rated Storage Energy	706 kWh
Nominal Voltage	614 V
System Voltage	DC 24 V
BMS Protection Level	IP67
Cooling Type	Intelligent temperature control liquid cooling
Recommended Charging Pile	720 kW
Charging Time	≤ 60 min (SOC12% ~ 95%)
DRIVE MOTOR	
Peak Power	180 kW
Protection Level	IP67
Ambient Temperature	- 40 ~ 85°C
Cooling Type	Intelligent temperature control liquid cooling
Altitude	≤ 5,000 m
HYDRAULIC MOTOR	
Peak Power	240 kW
Protection Level	IP67
Ambient Temperature	- 40 ~ 85°C
Cooling Type	Intelligent temperature control liquid cooling
Altitude	≤ 5,000 m
TRANSMISSION	
Manufacturer	LiuGong
Number of Speeds, fwd / rev	2 / 2
Maximum Travel Speed, fwd	36.5 km/h
Maximum Travel Speed, rev	36.5 km/h
Transmission Type	Fixed shaft power shift
AXLES	
Type	LiuGong wet axle
Axle Oscillation	± 9°
Tire Size	875/65R29 ★★ L-3
WORKING HYDRAULICS	
System	Variable displacement dual pump flow combination
Operation	Electric proportional fingertip control / Single electric-control joystick
Work Pump	Variable displacement piston pump
Work Pressure	31.5 MPa

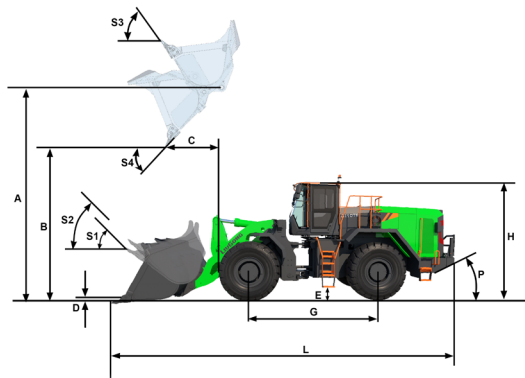

STEERING HYDRAULICS	
System	Load-Sensing
Steering Pump	Variable displacement piston pump
Steering Relief Pressure	24.5 MPa
BRAKES	
Service Brake Type	Full hydraulic wet brake
Service Brake Actuation	Single-pedal full hydraulic brake
Parking Brake Type	Caliper disc brake
Parking Brake Actuation	Electro-hydraulic control
PERFORMANCES	
Operating Weight	39,400 kg
Bucket Capacity	6.2 m³
Tipping Load - Straight	26,700 kg
Tipping Load - Full Turn	23,600 kg
Raise Time	5.0 s
Dump Time	1.6 s
Float Down Time	3.4 s
Fastest Total Cycle Time	10.0 s
Bucket Breakout Force	317 kN
A Maximum Hinge Pin Height	4,779 mm
B Dump Clearance at Full Height Discharge	3,350 mm
C Dump Reach at Full Height Discharge	1,640 mm
D Maximum Digging Depth, Bucket Level	127 mm
S ₁ Bucket Rollback at Ground Level	45°
S ₂ Bucket Rollback at Carry	49°
S ₃ Bucket Rollback at Maximum Height	64°
S ₄ Maximum Dump Angle at Full Height	45°
DIMENSIONS	
E Ground Clearance	442 mm
G Wheelbase	4,000 mm
H Cab Height	3,800 mm
J Wheel Tread	2,450 mm
K Width over Tires	3,325 mm
L Length with Bucket Down	10,735 mm
M Turn Angle, Either Side	40°
P Rear Angle of Departure	25°
R ₁ Turning Radius, Bucket Carry	8,123 mm
R ₂ Turning Radius, Outside of Tire	7,273 mm
W Width over Bucket	3,530 mm
SERVICE CAPACITIES	
Anti-freeze	100 L
Hydraulic Reservoir	450 L
Axle, Front / Rear	90 / 90 L
Transmission	23 L

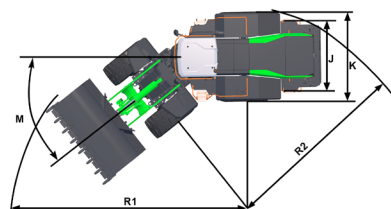

Guangxi Liugong Machinery Co., Ltd.

No. 1 Liutai Road, Liuzhou, Guangxi 545007, PR China
T: +86 772 3886124 E: overseas@liugong.com
www.liugong.com

Specifications and designs are subject to change without notice. Machines shown may include optional equipment. LiuGong standard and optional equipment may vary from region to region. Please consult your LiuGong dealer for information specific to your area.

07/2025 Designed by LiuGong
Replace the previous versions of 07/2025