



Engine	Cummins F3.8
Net Power	69.5 kW (93.2 hp / 94.5 ps) @ 2,200 rpm
Operating Weight	14,700 - 16,500 kg (32,408-36376 lbs)
Bucket Capacity	0.55 m ³

913FCR EXCAVATOR



SPECIFICATIONS

Operating weight 14,700-16,500 kg
(32,408-36,376 lbs)

Operating weight includes coolant, lubricants, full fuel tank, cab, standard shoes, boom, arm, bucket and operator 75 kg.

Bucket capacity 0.55 m³

ENGINE

Description

Cummins EU Stage III, turbocharged, 4 cylinder, 4 stroke, water cooled

Emission rating EU Stage III

Engine manufacturer Cummins

Engine model F3.8

Displacement 3.8 L (1 gal)

Rated speed 2,200 rpm

Engine Output - Net (SAE J1349 / ISO 9249) 69.5 kW (93.2 hp / 94.5 ps)

Engine Output - Gross (SAE J1995 / ISO 14396) 75 kW (100.6 hp / 101.9 ps)

Maximum torque 500 N·m (369 lbf·ft) @1,500 rpm

Bore × Stroke 102 × 115 mm (4" × 4.5")

UNDERCARRIAGE

Track shoe each side 44 (1.7")

Link pitch 175 mm (6.9" metal)

Shoe width, triple grouser 500/600/700 mm (20"/24"/28")

Bottom rollers each side 7

Top rollers each side 1

SWING SYSTEM

Swing speed 11.3 rpm

Swing torque 36,790 N·m (27,135 lbf·ft)

HYDRAULIC SYSTEM

Main pump

Type Two variable displacement piston pumps

Maximum flow 2 x 117 L/min (2 x 30.9 gal/min)

Relief valve setting

Implement 34.3 / 37 MPa (4,975 / 5,366 psi)

Travel circuit 34.3 MPa (4,975 psi)

Slew circuit 26.5 MPa (3,843 psi)

Pilot circuit 3.9 MPa (566 psi)

Hydraulic cylinders

Boom Cylinder – Bore × Stroke – Φ 105 × 1,000 mm (4.1"×3'3")

Arm Cylinder – Bore × Stroke – Φ 115 × 1,175 mm (4.5"×3'10")

Bucket Cylinder – Bore × Stroke – Φ 95 × 885 mm (3.7"×2'11")

ELECTRIC SYSTEM

System voltage 12 V

Batteries 2x12 V

Alternator 12 V - 70 A

Start motor 12 V - 4.8 kW (24 V - 6.4 hp)

SERVICE CAPACITIES

Fuel tank 200 L (52.8 gal)

Engine oil 12 L (3.2 gal)

Final drive (each) 2.5 L (0.7 gal)

Swing drive 3 L (0.8 gal)

Cooling system 20 L (5.3 gal)

Hydraulic reservoir 100 L (26.4 gal)

Hydraulic system total 160 L (42.3 gal)

DEF tank 25 L (6.6 gal)

SOUND PERFORMANCE

Interior Sound Power Level (ISO 6396) 72 dB(A)

Exterior Sound Power Level (ISO 6395) 99 dB(A)

DRIVE AND BRAKES

Description

Steering controlled by two hand levers with pedals.

Max. travel speed High: 4.9 km/h (3 mph)
Low: 2.9 km/h (1.8 mph)

Gradeability 35°/70%

Max. drawbar pull 122 kN (27,427 lbf)

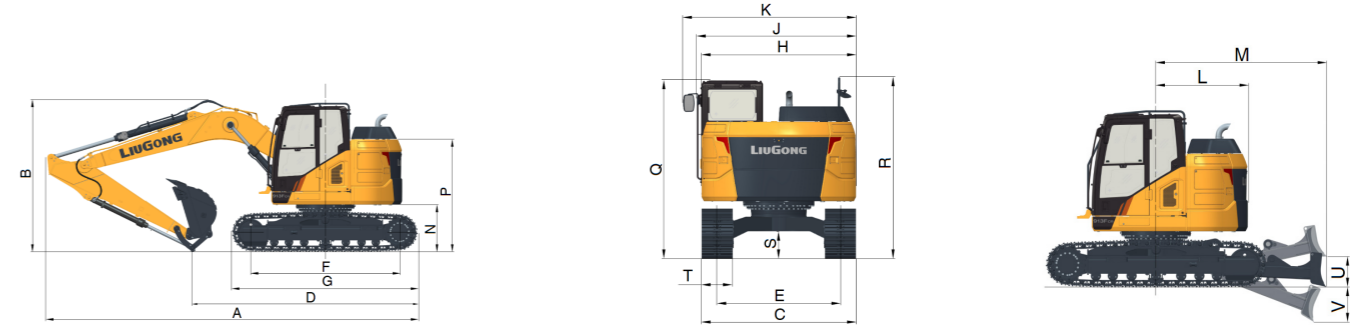

DIMENSIONS

Boom	4,600 mm	
Arm Options	2,500 mm	2,900 mm
A Shipping Length	7,295 mm	7,260 mm
B Shipping Height	2,980 mm	3,190 mm
C Undercarriage Width - 500 mm (20") shoes	2,490 mm	
600 mm (24") shoes	2,590 mm	
700 mm (28") shoes	2,690 mm	
D Shipping length on ground	4,435 mm	4,255 mm
E Track Gauge	1,990 mm	
F Length to Center of Rollers	2,930 mm	
G Track Length	3,660 mm	
H Overall Width of Upper Structure	2,490 mm	
J Overall Width of Upper Structure including Cab handrail	2,570 mm	
K Overall Width of Upper Structure including Cab rearview mirror	2,790 mm	
L Tail Swing Radius	1,525 mm	
M Distance of swing center to blade	2,805 mm	
N Counterweight Ground Clearance	925 mm	
P Overall Height of Counterweight	2,205 mm	
Q Overall Height of Cab	2,875 mm	
Overall Height of Cab including Halo	3,020 mm	
Overall Height of Cab including FOP's Guard	3,010 mm	
R Overall Height of Platform handrail	2,925 mm	
S Min. Ground Clearance	440 mm	
T Track Shoe Width	500 mm	
U Blade, max. lifting height	500 mm	
V Blade, max. digging depth	575 mm	

MACHINE WEIGHTS & GROUND PRESSURE

Shoe width	Operating weight	Ground pressure	Overall width
	Operating weight, including 2,500mm arm, 450 kg bucket, additional weight with blade: +1,000 kg.		
500 mm	14,700 kg	44.9 kPa	2,490 mm
600 mm	14,900 kg	37.9 kPa	2,590 mm
700 mm	15,100 kg	32.9 kPa	2,690 mm
500 mm rubber crawler pads	14,700 kg	44.6 kPa	2,490 mm

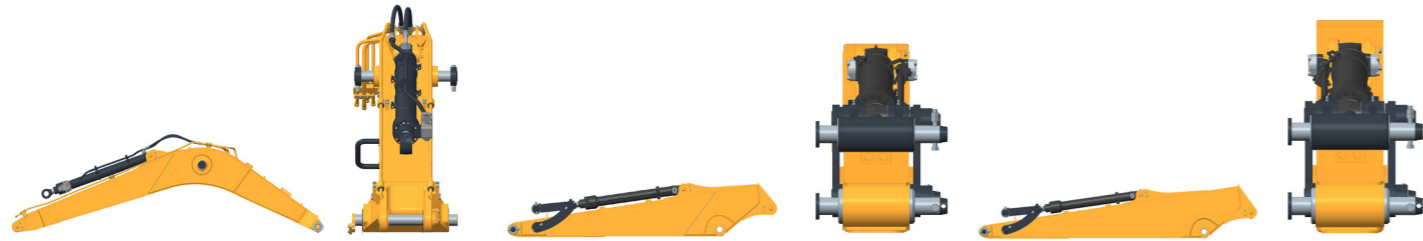

ARM DIMENSIONS

Arm	2,500 mm	2,900 mm
Length	3,300 mm	3,700 mm
Height	650 mm	700 mm
Width	450 mm	450 mm
Weight	640 kg	670 kg

Cylinder, linkage and pin included.

BOOM DIMENSIONS

Boom	/
Length	4,800 mm
Height	1,500 mm
Width	750 mm
Weight	1,170 kg

Cylinder, piping and pin included. Boom cylinder pin excluded.

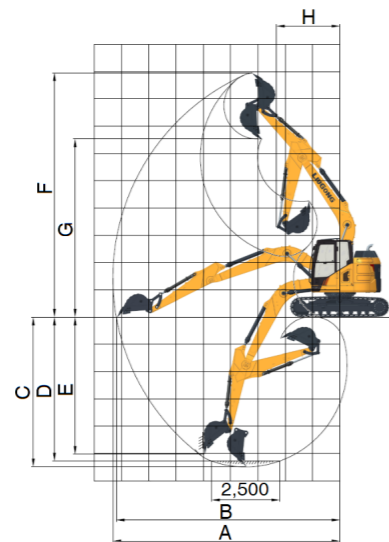

WORKING RANGE

MONO BOOM		/
Arm		2,500/2,900 mm
A. Max. Digging Reach		8,315/8,705 mm
B. Max. Digging Reach on Ground		8,190/8,585 mm
C. Max. Digging Depth		5,490/5,890 mm
D. Max. Digging Depth, 2.5m (8') level		5,275/5,700 mm
E. Max. Vertical Wall Digging Depth		5,030/5,415 mm
F. Max. Cutting Height		8,960/9,260 mm
G. Max. Dumping Height		6,530/6,835 mm
H. Min. Front Swing Radius		2,325/2,430 mm
Bucket Digging Force (ISO)	Normal	89.8 kN
	Power Boost	96.9 kN
Arm Digging Force (ISO)	Normal	64.9/58 kN
	Power Boost	70/63.5 kN
Bucket Capacity		0.5 m ³
Bucket Tip Radius		1,055 mm

Lifting capacity at the arm end without bucket. For lifting capacity including bucket, weight of the bucket or the bucket with quick coupler must be deducted from the lifting capacities. Lifting capacities are based on the machine standing on a firm, uniform supporting surface.



- Do not attempt to lift or hold any load that is greater than these rated values at their specified load radius and height. Weight of all accessories must be deducted from the above lifting capacities.
- The rated loads are in compliance with ISO 10567 Hydraulic Excavator Lift Capacity Rating Standard. They do not exceed 87% of hydraulic lifting capacity or 75% tipping load.
- Ratings at bucket lift hook.
- Lifting capacities are based on machine standing on level, firm and uniform ground.
- *Indicates the load is limited by hydraulic capacity rather than tipping capacity.
- Operator should be fully acquainted with the Operator's and Maintenance Instructions before operating this machine and rules for the safe operation of equipment should be adhered to at all times.

LIFTING CAPACITY (METRIC)

913FCR with 500 mm Shoes, 4,600 mm Boom, 2,500 mm Arm	Conditions	
A: load radius B: load point height C: Lifting capacity rating Cf: Rated loads over front Cs: Rated loads over side	Boom length: 4,600 mm Arm length: 2,500 mm Bucket: None counterweight: 3,000 kg Shoes: 500 mm triple grouser shoes Blade: None	

B/A (m)	1.5m		3.0m		4.5m		6m		MAX REACH			
	Cf	Cs	Cf	Cs	Cf	Cs	Cf	Cs	Cf	Cs	Distance	
6	kg				*3,600	*3,600			*2,050	*2,050	5.4	
4.5	kg				*3,800	3,600	*3,350	2,250	*2,350	2,100	6.3	
3	kg		*6,150	*6,150	*4,500	3,400	3,550	2,200	*1,950	1,750	6.9	
1.5	kg		*8,400	5,500	5,300	3,150	3,450	2,100	*2,550	1,650	7	
ground	kg		*7,200	5,150	5,100	2,950	3,350	2,000	*2,450	1,650	6.9	
-1.5	kg	*5,150	*5,150	*8,600	5,100	5,000	2,850	3,300	2,000	*2,800	1,850	6.4
-3	kg	*9,100	*9,100	*7,150	5,200	*4,900	2,900		*3,750	2,300	5.4	

LIFTING CAPACITY (METRIC)

913FCR with 600 mm Shoes, 4,600 mm Boom, 2,500 mm Arm	Conditions	
A: load radius B: load point height C: Lifting capacity rating Cf: Rated loads over front Cs: Rated loads over side	Boom length: 4,600 mm Arm length: 2,500 mm Bucket: None counterweight: 3,000 kg Shoes: 600 mm triple grouser shoes Blade: None	

B/A (m)	1.5m		3.0m		4.5m		6m		MAX REACH			
	Cf	Cs	Cf	Cs	Cf	Cs	Cf	Cs	Cf	Cs	Distance	
6	kg				*3,600	*3,600			*2,050	*2,050	5.4	
4.5	kg				*3,800	3,650	*3,350	2,300	*2,350	2,100	6.3	
3	kg		*6,150	*6,150	*4,500	3,450	3,600	2,250	*1,950	1,800	6.9	
1.5	kg		*8,400	5,600	*5,350	3,200	3,500	2,150	*2,550	1,700	7	
ground	kg		*7,200	5,250	5,200	3,000	3,400	2,050	*2,450	1,700	6.9	
-1.5	kg	*5,150	*5,150	*8,600	5,200	5,100	2,950	3,350	2,000	*2,800	1,850	6.4
-3	kg	*9,100	*9,100	*7,150	5,300	*4,900	2,950		*3,750	2,350	5.4	



Lifting capacity at the arm end without bucket.
For lifting capacity including bucket, weight of the bucket or the bucket with quick coupler must be deducted from the lifting capacities.
Lifting capacities are based on the machine standing on a firm, uniform supporting surface.



Rating over-front (Cf)



Rating over-side (Cs)

- Do not attempt to lift or hold any load that is greater than these rated values at their specified load radius and height. Weight of all accessories must be deducted from the above lifting capacities.
- The rated loads are in compliance with ISO 10567 Hydraulic Excavator Lift Capacity Rating Standard. They do not exceed 87% of hydraulic lifting capacity or 75% tipping load.
- Ratings at bucket lift hook.
- Lifting capacities are based on machine standing on level, firm and uniform ground.
- *Indicates the load is limited by hydraulic capacity rather than tipping capacity.
- Operator should be fully acquainted with the Operator's and Maintenance Instructions before operating this machine and rules for the safe operation of equipment should be adhered to at all times.

LIFTING CAPACITY (METRIC)

913FCR with 700 mm Shoes, 4,600 mm Boom, 2,500 mm Arm

Conditions

Boom length: 4,600 mm
Arm length: 2,500 mm
Bucket: None
counterweight: 3,000 kg
Shoes: 700 mm triple grouser shoes
Blade: None

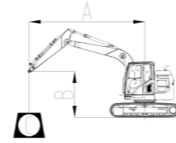

A: load radius
B: load point height
C: Lifting capacity rating
Cf: Rated loads over front
Cs: Rated loads over side

B/A (m)	1.5m		3.0m		4.5m		6m		MAX REACH			
	Cf	Cs	Cf	Cs	Cf	Cs	Cf	Cs	Cf	Cs	Distance	
6	kg				*3,600	*3,600			*2,050	*2,050	5.4	
4.5	kg				*3,800	3,700	*3,350	2,350	*2,350	2,150	6.3	
3	kg		*6,150	*6,150	*4,500	3,500	3,700	2,300	*1,950	1,850	6.9	
1.5	kg		*8,400	5,700	*5,350	3,250	3,550	2,200	*2,550	1,750	7	
ground	kg		*7,200	5,350	5,250	3,050	3,450	2,100	*2,450	1,750	6.9	
-1.5	kg	*5,150	*5,150	*8,600	5,300	5,200	3,000	3,450	2,050	*2,800	1,900	6.4
-3	kg	*9,100	*9,100	*7,150	5,400	*4,900	3,000		*3,750	2,400	5.4	

LIFTING CAPACITY (METRIC)

913FCR with 500 mm Shoes, 4,600 mm Boom, 2,500 mm Arm

Conditions

Boom length: 4,600 mm
Arm length: 2,500 mm
Bucket: None
counterweight: 3,000 kg
Shoes: 500 mm rubber track shoes
Blade: None

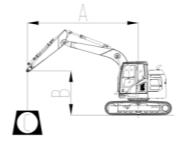

A: load radius
B: load point height
C: Lifting capacity rating
Cf: Rated loads over front
Cs: Rated loads over side

B/A (m)	1.5m		3.0m		4.5m		6m		MAX REACH			
	Cf	Cs	Cf	Cs	Cf	Cs	Cf	Cs	Cf	Cs	Distance	
6	kg				*3,600	*3,600			*2,050	*2,050	5.4	
4.5	kg				*3,800	3,600	*3,350	2,250	*2,350	2,050	6.3	
3	kg		*6,150	*6,150	*4,500	3,400	3,550	2,200	*1,950	1,750	6.9	
1.5	kg		*8,400	5,450	5,300	3,100	3,450	2,100	*2,550	1,650	7	
ground	kg		*7,200	5,150	5,050	2,950	3,350	2,000	*2,450	1,650	6.9	
-1.5	kg	*5,150	*5,150	*8,600	5,100	4,950	2,850	3,300	1,950	*2,800	1,800	6.4
-3	kg	*9,100	*9,100	*7,150	5,200	*4,900	2,900		*3,750	2,300	5.4	

Lifting capacity at the arm end without bucket.
For lifting capacity including bucket, weight of the bucket or the bucket with quick coupler must be deducted from the lifting capacities.
Lifting capacities are based on the machine standing on a firm, uniform supporting surface.



Rating over-front (Cf)



Rating over-side (Cs)

- Do not attempt to lift or hold any load that is greater than these rated values at their specified load radius and height. Weight of all accessories must be deducted from the above lifting capacities.
- The rated loads are in compliance with ISO 10567 Hydraulic Excavator Lift Capacity Rating Standard. They do not exceed 87% of hydraulic lifting capacity or 75% tipping load.
- Ratings at bucket lift hook.
- Lifting capacities are based on machine standing on level, firm and uniform ground.
- *Indicates the load is limited by hydraulic capacity rather than tipping capacity.
- Operator should be fully acquainted with the Operator's and Maintenance Instructions before operating this machine and rules for the safe operation of equipment should be adhered to at all times.

LIFTING CAPACITY (METRIC)

913FCR with 500 mm Shoes, 4,600 mm Boom, 2,900 mm Arm

Conditions

Boom length: 4,600 mm
Arm length: 2,900 mm
Bucket: None
counterweight: 3,000 kg
Shoes: 500 mm triple grouser shoes
Blade: None

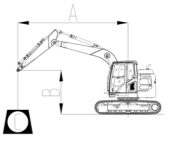

A: load radius
B: load point height
C: Lifting capacity rating
Cf: Rated loads over front
Cs: Rated loads over side

B/A (m)	1.5m		3.0m		4.5m		6m		MAX REACH			
	Cf	Cs	Cf	Cs	Cf	Cs	Cf	Cs	Cf	Cs	Distance	
6	kg				*3,200	*3,200			*1,700	*1,700	5.9	
4.5	kg				*3,450	*3,450	*3,350	2,300	*1,650	*1,650	6.8	
3	kg		*5,400	*5,400	*4,150	3,450	3,600	2,250	*1,600	*1,600	7.3	
1.5	kg		*7,850	5,650	*5,100	3,200	3,450	2,100	*2,000	1,550	7.4	
ground	kg		*7,800	5,200	5,100	2,950	3,350	2,000	*1,950	1,550	7.3	
-1.5	kg	*4,700	*4,700	*8,850	5,100	5,000	2,850	3,300	1,950	*2,450	1,650	6.8
-3	kg	*7,900	*7,900	*7,650	5,150	5,000	2,850		*3,300	2,050	5.9	
-4.5	kg		*5,050	*5,050					*3,100	*3,100	4.4	

LIFTING CAPACITY (METRIC)

913FCR with 600 mm Shoes, 4,600 mm Boom, 2,900 mm Arm

Conditions

Boom length: 4,600 mm
Arm length: 2,900 mm
Bucket: None
counterweight: 3,000 kg
Shoes: 600 mm triple grouser shoes
Blade: None

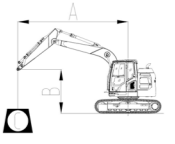

A: load radius
B: load point height
C: Lifting capacity rating
Cf: Rated loads over front
Cs: Rated loads over side

B/A (m)	1.5m		3.0m		4.5m		6m		MAX REACH			
	Cf	Cs	Cf	Cs	Cf	Cs	Cf	Cs	Cf	Cs	Distance	
6	kg				*3,200	*3,200			*1,700	*1,700	5.9	
4.5	kg				*3,450	*3,450	*3,350	2,350	*1,650	*1,650	6.8	
3	kg		*5,400	*5,400	*4,150	3,500	*3,600	2,300	*1,600	*1,600	7.3	
1.5	kg		*7,850	5,750	*5,100	3,250	3,550	2,150	*2,000	1,600	7.4	
ground	kg		*7,800	5,300	5,200	3,050	3,400	2,050	*1,950	1,550	7.3	
-1.5	kg	*4,700	*4,700	*8,850	5,200	5,100	2,900	3,350	2,000	*2,450	1,700	6.8
-3	kg	*7,900	*7,900	*7,650	5,250	5,100	2,950		*3,300	2,100	5.9	
-4.5	kg		*5,050	*5,050					*3,100	*3,100	4.4	



Lifting capacity at the arm end without bucket.
For lifting capacity including bucket, weight of the bucket or the bucket with quick coupler must be deducted from the lifting capacities.
Lifting capacities are based on the machine standing on a firm, uniform supporting surface.



Rating over-front (Cf)



Rating over-side (Cs)

- Do not attempt to lift or hold any load that is greater than these rated values at their specified load radius and height. Weight of all accessories must be deducted from the above lifting capacities.
- The rated loads are in compliance with ISO 10567 Hydraulic Excavator Lift Capacity Rating Standard. They do not exceed 87% of hydraulic lifting capacity or 75% tipping load.
- Ratings at bucket lift hook.
- Lifting capacities are based on machine standing on level, firm and uniform ground.
- *Indicates the load is limited by hydraulic capacity rather than tipping capacity.
- Operator should be fully acquainted with the Operator's and Maintenance Instructions before operating this machine and rules for the safe operation of equipment should be adhered to at all times.

LIFTING CAPACITY (METRIC)

913FCR with 700 mm Shoes, 4,600 mm Boom, 2,900 mm Arm

Conditions

Boom length: 4,600 mm
Arm length: 2,900 mm
Bucket: None
counterweight: 3,000 kg
Shoes: 700 mm triple grouser shoes
Blade: None

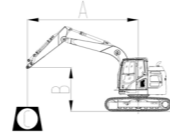

A: load radius
B: load point height
C: Lifting capacity rating
Cf: Rated loads over front
Cs: Rated loads over side

B/A (m)	1.5m		3.0m		4.5m		6m		MAX REACH			
	Cf	Cs	Cf	Cs	Cf	Cs	Cf	Cs	Cf	Cs	Distance	
6	kg				*3,200	*3,200			*1,700	*1,700	5.9	
4.5	kg				*3,450	*3,450	*3,350	2,400	*1,650	*1,650	6.8	
3	kg		*5,400	*5,400	*4,150	3,600	*3,600	2,300	*1,600	*1,600	7.3	
1.5	kg		*7,850	5,900	*5,100	3,300	3,600	2,200	*2,000	1,600	7.4	
ground	kg		*7,800	5,400	5,300	3,100	3,500	2,100	*1,950	1,600	7.3	
-1.5	kg	*4,700	*4,700	*8,850	5,300	5,200	3,000	3,400	2,050	*2,450	1,750	6.8
-3	kg	*7,900	*7,900	*7,650	5,350	5,200	3,000		*3,300	2,100	5.9	
-4.5	kg		*5,050	*5,050					*3,100	*3,100	4.4	

LIFTING CAPACITY (METRIC)

913FCR with 500 mm Shoes, 4,600 mm Boom, 2,900 mm Arm

Conditions

Boom length: 4,600 mm
Arm length: 2,900 mm
Bucket: None
counterweight: 3,000 kg
Shoes: 500 mm rubber track shoes
Blade: None

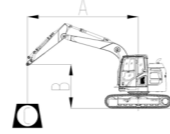

A: load radius
B: load point height
C: Lifting capacity rating
Cf: Rated loads over front
Cs: Rated loads over side

B/A (m)	1.5m		3.0m		4.5m		6m		MAX REACH			
	Cf	Cs	Cf	Cs	Cf	Cs	Cf	Cs	Cf	Cs	Distance	
6	kg				*3,200	*3,200			*1,700	*1,700	5.9	
4.5	kg				*3,450	*3,450	*3,350	2,300	*1,650	*1,650	6.8	
3	kg		*5,400	*5,400	*4,150	3,450	3,600	2,250	*1,600	*1,600	7.3	
1.5	kg		*7,850	5,650	*5,100	3,150	3,450	2,100	*2,000	1,550	7.4	
ground	kg		*7,800	5,200	5,100	2,950	3,350	2,000	*1,950	1,550	7.3	
-1.5	kg	*4,700	*4,700	*8,850	5,050	4,950	2,850	3,300	1,950	*2,450	1,650	6.8
-3	kg	*7,900	*7,900	*7,650	5,100	5,000	2,850		*3,300	2,000	5.9	
-4.5	kg		*5,050	*5,050					*3,100	*3,100	4.4	

Lifting capacity at the arm end without bucket.
For lifting capacity including bucket, weight of the bucket or the bucket with quick coupler must be deducted from the lifting capacities.
Lifting capacities are based on the machine standing on a firm, uniform supporting surface.



Rating over-front (Cf)



Rating over-side (Cs)

- Do not attempt to lift or hold any load that is greater than these rated values at their specified load radius and height. Weight of all accessories must be deducted from the above lifting capacities.
- The rated loads are in compliance with ISO 10567 Hydraulic Excavator Lift Capacity Rating Standard. They do not exceed 87% of hydraulic lifting capacity or 75% tipping load.
- Ratings at bucket lift hook.
- Lifting capacities are based on machine standing on level, firm and uniform ground.
- *Indicates the load is limited by hydraulic capacity rather than tipping capacity.
- Operator should be fully acquainted with the Operator's and Maintenance Instructions before operating this machine and rules for the safe operation of equipment should be adhered to at all times.

LIFTING CAPACITY (METRIC)

913FCR with 500 mm Shoes, 4,600 mm Boom, 2,500 mm Arm

Conditions

Boom length: 4,600 mm
Arm length: 2,500 mm
Bucket: None
counterweight: 3,000 kg
Shoes: 500 mm triple grouser shoes
Blade: YES

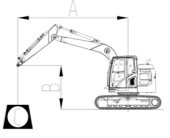

A: load radius
B: load point height
C: Lifting capacity rating
Cf: Rated loads over front
Cs: Rated loads over side

Blade Down												
B/A (m)	1.5m		3.0m		4.5m		6m		MAX REACH			
	Cf	Cs	Cf	Cs	Cf	Cs	Cf	Cs	Cf	Cs	Distance	
6	kg				*3,600	3,600			*2,050	*2,050	5.4	
4.5	kg				*3,800	3,550	*3,350	2,200	*2,350	2,050	6.3	
3	kg		*6,150	*6,150	*4,500	3,300	*3,800	2,150	*1,950	1,700	6.9	
1.5	kg		*8,400	5,350	*5,350	3,050	*4,150	2,050	*2,550	1,650	7	
ground	kg		*7,200	5,050	*5,850	2,850	*4,350	1,950	*2,450	1,600	6.9	
-1.5	kg	*5,150	*5,150	*8,600	5,000	*5,800	2,800	*4,200	1,950	*2,800	1,800	6.4
-3	kg	*9,100	*9,100	*7,150	5,100	*4,900	2,850		*3,750	2,250	5.4	

Blade Up												
B/A (m)	1.5m		3.0m		4.5m		6m		MAX REACH			
	Cf	Cs	Cf	Cs	Cf	Cs	Cf	Cs	Cf	Cs	Distance	
6	kg				*3,600	3,600			*2,050	*2,050	5.4	
4.5	kg				*3,800	3,550	*3,350	2,200	*2,350	2,050	6.3	
3	kg		*6,150	*6,150	*4,500	3,300	3,600	2,150	*1,950	1,700	6.9	
1.5	kg		*8,400	5,350	5,350	3,050	3,450	2,050	*2,550	1,650	7	
ground	kg		*7,200	5,050	5,100	2,850	3,350	1,950	*2,450	1,600	6.9	
-1.5	kg	*5,150	*5,150	*8,600	5,000	5,000	2,800	3,300	1,950	*2,800	1,800	6.4
-3	kg	*9,100	*9,100	*7,150	5,100	*4,900	2,850		*3,750	2,250	5.4	



Lifting capacity at the arm end without bucket.
For lifting capacity including bucket, weight of the bucket or the bucket with quick coupler must be deducted from the lifting capacities.
Lifting capacities are based on the machine standing on a firm, uniform supporting surface.



Rating over-front (Cf)



Rating over-side (Cs)

- Do not attempt to lift or hold any load that is greater than these rated values at their specified load radius and height. Weight of all accessories must be deducted from the above lifting capacities.
- The rated loads are in compliance with ISO 10567 Hydraulic Excavator Lift Capacity Rating Standard. They do not exceed 87% of hydraulic lifting capacity or 75% tipping load.
- Ratings at bucket lift hook.
- Lifting capacities are based on machine standing on level, firm and uniform ground.
- *Indicates the load is limited by hydraulic capacity rather than tipping capacity.
- Operator should be fully acquainted with the Operator's and Maintenance Instructions before operating this machine and rules for the safe operation of equipment should be adhered to at all times.

LIFTING CAPACITY (METRIC)

913FCR with 600 mm Shoes, 4,600 mm Boom, 2,500 mm Arm

Conditions

Boom length: 4,600 mm
Arm length: 2,500 mm
Bucket: None
counterweight: 3,000 kg
Shoes: 600 mm triple grouser shoes
Blade: YES

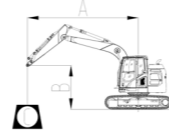

A: load radius
B: load point height
C: Lifting capacity rating
Cf: Rated loads over front
Cs: Rated loads over side

Blade Down

B/A (m)		1.5m		3.0m		4.5m		6m		MAX REACH		
		Cf	Cs	Cf	Cs	Cf	Cs	Cf	Cs	Cf	Cs	Distance
6	kg					*3,600	*3,600			*2,050	*2,050	5.4
4.5	kg					*3,800	3,600	*3,350	2,250	*2,350	2,050	6.3
3	kg			*6,150	*6,150	*4,500	3,400	*3,800	2,200	*1,950	1,750	6.9
1.5	kg			*8,400	5,450	*5,350	3,100	*4,150	2,100	*2,550	1,650	7
ground	kg			*7,200	5,100	*5,850	2,950	*4,350	2,000	*2,450	1,650	6.9
-1.5	kg	*5,150	*5,150	*8,600	5,050	*5,800	2,850	*4,200	1,950	*2,800	1,800	6.4
-3	kg	*9,100	*9,100	*7,150	5,150	*4,900	2,900			*3,750	2,300	5.4

Blade Up

B/A (m)		1.5m		3.0m		4.5m		6m		MAX REACH		
		Cf	Cs	Cf	Cs	Cf	Cs	Cf	Cs	Cf	Cs	Distance
6	kg					*3,600	*3,600			*2,050	*2,050	5.4
4.5	kg					*3,800	3,600	*3,350	2,250	*2,350	2,050	6.3
3	kg			*6,150	*6,150	*4,500	3,400	3,650	2,200	*1,950	1,750	6.9
1.5	kg			*8,400	5,450	*5,350	3,100	3,500	2,100	*2,550	1,650	7
ground	kg			*7,200	5,100	5,200	2,950	3,400	2,000	*2,450	1,650	6.9
-1.5	kg	*5,150	*5,150	*8,600	5,050	5,100	2,850	3,400	1,950	*2,800	1,800	6.4
-3	kg	*9,100	*9,100	*7,150	5,150	*4,900	2,900			*3,750	2,300	5.4

Lifting capacity at the arm end without bucket.
For lifting capacity including bucket, weight of the bucket or the bucket with quick coupler must be deducted from the lifting capacities.
Lifting capacities are based on the machine standing on a firm, uniform supporting surface.



Rating over-front (Cf)



Rating over-side (Cs)

- Do not attempt to lift or hold any load that is greater than these rated values at their specified load radius and height. Weight of all accessories must be deducted from the above lifting capacities.
- The rated loads are in compliance with ISO 10567 Hydraulic Excavator Lift Capacity Rating Standard. They do not exceed 87% of hydraulic lifting capacity or 75% tipping load.
- Ratings at bucket lift hook.
- Lifting capacities are based on machine standing on level, firm and uniform ground.
- *Indicates the load is limited by hydraulic capacity rather than tipping capacity.
- Operator should be fully acquainted with the Operator's and Maintenance Instructions before operating this machine and rules for the safe operation of equipment should be adhered to at all times.

LIFTING CAPACITY (METRIC)

913FCR with 500 mm Shoes, 4,600 mm Boom, 2,500 mm Arm

Conditions

Boom length: 4,600 mm
Arm length: 2,500 mm
Bucket: None
counterweight: 3,000 kg
Shoes: 700 mm triple grouser shoes
Blade: YES

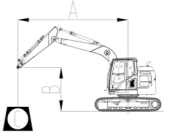

A: load radius
B: load point height
C: Lifting capacity rating
Cf: Rated loads over front
Cs: Rated loads over side

Blade Down

B/A (m)		1.5m		3.0m		4.5m		6m		MAX REACH		
		Cf	Cs	Cf	Cs	Cf	Cs	Cf	Cs	Cf	Cs	Distance
6	kg					*3,600	*3,600			*2,050	*2,050	5.4
4.5	kg					*3,800	3,650	*3,350	2,300	*2,350	2,100	6.3
3	kg			*6,150	*6,150	*4,500	3,450	*3,800	2,250	*1,950	1,800	6.9
1.5	kg			*8,400	5,550	*5,350	3,150	*4,150	2,150	*2,550	1,700	7
ground	kg			*7,200	5,200	*5,850	3,000	*4,350	2,050	*2,450	1,700	6.9
-1.5	kg	*5,150	*5,150	*8,600	5,150	*5,800	2,900	*4,200	2,000	*2,800	1,850	6.4
-3	kg	*9,100	*9,100	*7,150	5,250	*4,900	2,950			*3,750	2,350	5.4

Blade Up

B/A (m)		1.5m		3.0m		4.5m		6m		MAX REACH		
		Cf	Cs	Cf	Cs	Cf	Cs	Cf	Cs	Cf	Cs	Distance
6	kg					*3,600	*3,600			*2,050	*2,050	5.4
4.5	kg					*3,800	3,650	*3350	2,300	*2,350	2,100	6.3
3	kg			*6,150	*6,150	*4,500	3,450	3,700	2,250	*1,950	1,800	6.9
1.5	kg			*8,400	5,550	*5,350	3,150	3,600	2,150	*2,550	1,700	7
ground	kg			*7,200	5,200	5,300	3,000	3,500	2,050	*2,450	1,700	6.9
-1.5	kg	*5,150	*5,150	*8,600	5,150	5,200	2,900	3,450	2,000	*2,800	1,850	6.4
-3	kg	*9,100	*9,100	*7,150	5,250	*4,900	2,950			*3,750	2,350	5.4



Lifting capacity at the arm end without bucket.
For lifting capacity including bucket, weight of the bucket or the bucket with quick coupler must be deducted from the lifting capacities.
Lifting capacities are based on the machine standing on a firm, uniform supporting surface.



Rating over-front (Cf)



Rating over-side (Cs)

- Do not attempt to lift or hold any load that is greater than these rated values at their specified load radius and height. Weight of all accessories must be deducted from the above lifting capacities.
- The rated loads are in compliance with ISO 10567 Hydraulic Excavator Lift Capacity Rating Standard. They do not exceed 87% of hydraulic lifting capacity or 75% tipping load.
- Ratings at bucket lift hook.
- Lifting capacities are based on machine standing on level, firm and uniform ground.
- *Indicates the load is limited by hydraulic capacity rather than tipping capacity.
- Operator should be fully acquainted with the Operator's and Maintenance Instructions before operating this machine and rules for the safe operation of equipment should be adhered to at all times.

LIFTING CAPACITY (METRIC)

913FCR with 600 mm Shoes, 4,600 mm Boom, 2,500 mm Arm

Conditions

Boom length: 4,600 mm
Arm length: 2,500 mm
Bucket: None
counterweight: 3,000 kg
Shoes: 500 mm rubber track shoes
Blade: YES

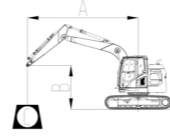

A: load radius
B: load point height
C: Lifting capacity rating
Cf: Rated loads over front
Cs: Rated loads over side

Blade Down

B/A (m)	1.5m		3.0m		4.5m		6m		MAX REACH			
	Cf	Cs	Cf	Cs	Cf	Cs	Cf	Cs	Cf	Cs	Distance	
6	kg				*3,600	3,600			*2,050	*2,050	5.4	
4.5	kg				*3,800	3,500	*3,350	2,200	*2,350	2,050	6.3	
3	kg		*6,150	6,100	*4,500	3,300	*3,800	2,150	*1,950	1,700	6.9	
1.5	kg		*8,400	5,350	*5,350	3,050	*4,150	2,050	*2,550	1,600	7	
ground	kg		*7,200	5,000	*5,850	2,850	*4,350	1,950	*2,450	1,600	6.9	
-1.5	kg	*5,150	*5,150	*8,600	4,950	*5,800	2,800	*4,200	1,900	*2,800	1,750	6.4
-3	kg	*9,100	*9,100	*7,150	5,050	*4,900	2,800		*3,750	2,250	5.4	

Blade Up

B/A (m)	1.5m		3.0m		4.5m		6m		MAX REACH			
	Cf	Cs	Cf	Cs	Cf	Cs	Cf	Cs	Cf	Cs	Distance	
6	kg				*3,600	3,600			*2,050	*2,050	5.4	
4.5	kg				*3,800	3,500	*3,350	2,200	*2,350	2,050	6.3	
3	kg		*6,150	6,100	*4,500	3,300	3,550	2,150	*1,950	1,700	6.9	
1.5	kg		*8,400	5,350	5,300	3,050	3,450	2,050	*2,550	1,600	7	
ground	kg		*7,200	5,000	5,100	2,850	3,350	1,950	*2,450	1,600	6.9	
-1.5	kg	*5,150	*5,150	*8,600	4,950	5,000	2,800	3,300	1,900	*2,800	1,750	6.4
-3	kg	*9,100	*9,100	*7,150	5,050	*4,900	2,800		*3,750	2,250	5.4	

Lifting capacity at the arm end without bucket.
For lifting capacity including bucket, weight of the bucket or the bucket with quick coupler must be deducted from the lifting capacities.
Lifting capacities are based on the machine standing on a firm, uniform supporting surface.



Rating over-front (Cf)



Rating over-side (Cs)

- Do not attempt to lift or hold any load that is greater than these rated values at their specified load radius and height. Weight of all accessories must be deducted from the above lifting capacities.
- The rated loads are in compliance with ISO 10567 Hydraulic Excavator Lift Capacity Rating Standard. They do not exceed 87% of hydraulic lifting capacity or 75% tipping load.
- Ratings at bucket lift hook.
- Lifting capacities are based on machine standing on level, firm and uniform ground.
- *Indicates the load is limited by hydraulic capacity rather than tipping capacity.
- Operator should be fully acquainted with the Operator's and Maintenance Instructions before operating this machine and rules for the safe operation of equipment should be adhered to at all times.

LIFTING CAPACITY (METRIC)

913FCR with 500 mm Shoes, 4,600 mm Boom, 2,900 mm Arm

Conditions

Boom length: 4,600 mm
Arm length: 2,900 mm
Bucket: None
counterweight: 3,000 kg
Shoes: 500 mm triple grouser shoes
Blade: YES

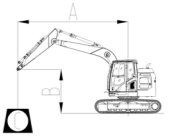

A: load radius
B: load point height
C: Lifting capacity rating
Cf: Rated loads over front
Cs: Rated loads over side

Blade Down

B/A (m)	1.5m		3.0m		4.5m		6m		MAX REACH			
	Cf	Cs	Cf	Cs	Cf	Cs	Cf	Cs	Cf	Cs	Distance	
6	kg				*3,200	*3,200			*1,700	*1,700	5.9	
4.5	kg				*3,450	*3,450	*3,350	2,250	*1,650	*1,650	6.8	
3	kg		*5,400	*5,400	*4,150	3,400	*3,600	2,200	*1,600	1,600	7.3	
1.5	kg		*7,850	5,550	*5,100	3,100	*4,000	2,050	*2,000	1,500	7.4	
ground	kg		*7,800	5,050	*5,750	2,900	*4,300	1,950	*1,950	1,500	7.3	
-1.5	kg	*4,700	*4,700	*8,850	4,950	*5,850	2,800	*4,250	1,900	*2,450	1,600	6.8
-3	kg	*7,900	*7,900	*7,650	5,000	*5,250	2,800		*3,300	2,000	5.9	
-4.5	kg		*5,050	*5,050					*3,100	3,050	4.4	

Blade Up

B/A (m)	1.5m		3.0m		4.5m		6m		MAX REACH			
	Cf	Cs	Cf	Cs	Cf	Cs	Cf	Cs	Cf	Cs	Distance	
6	kg				*3,200	*3,200			*1,700	*1,700	5.9	
4.5	kg				*3,450	*3,450	*3,350	2,250	*1,650	*1,650	6.8	
3	kg		*5,400	*5,400	*4,150	3,400	*3,600	2,200	*1,600	1,600	7.3	
1.5	kg		*7,850	5,550	*5,100	3,100	3,500	2,050	*2,000	1,500	7.4	
ground	kg		*7,800	5,050	5,150	2,900	3,350	1,950	*1,950	1,500	7.3	
-1.5	kg	*4,700	*4,700	*8,850	4,950	5,000	2,800	3,300	1,900	*2,450	1,600	6.8
-3	kg	*7,900	*7,900	*7,650	5,000	5,000	2,800		*3,300	2,000	5.9	
-4.5	kg		*5,050	*5,050					*3,100	3,050	4.4	



Lifting capacity at the arm end without bucket.
For lifting capacity including bucket, weight of the bucket or the bucket with quick coupler must be deducted from the lifting capacities.
Lifting capacities are based on the machine standing on a firm, uniform supporting surface.



Rating over-front (Cf)



Rating over-side (Cs)

- Do not attempt to lift or hold any load that is greater than these rated values at their specified load radius and height. Weight of all accessories must be deducted from the above lifting capacities.
- The rated loads are in compliance with ISO 10567 Hydraulic Excavator Lift Capacity Rating Standard. They do not exceed 87% of hydraulic lifting capacity or 75% tipping load.
- Ratings at bucket lift hook.
- Lifting capacities are based on machine standing on level, firm and uniform ground.
- *Indicates the load is limited by hydraulic capacity rather than tipping capacity.
- Operator should be fully acquainted with the Operator's and Maintenance Instructions before operating this machine and rules for the safe operation of equipment should be adhered to at all times.

LIFTING CAPACITY (METRIC)

913FCR with 600 mm Shoes, 4,600 mm Boom, 2,900 mm Arm

Conditions

Boom length: 600 mm
Arm length: 2,900 mm
Bucket: None
counterweight: 3,000 kg
Shoes: 600 mm triple grouser shoes
Blade: YES

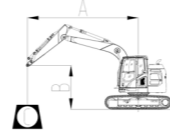

A: load radius
B: load point height
C: Lifting capacity rating
Cf: Rated loads over front
Cs: Rated loads over side

Blade Down

B/A (m)	1.5m		3.0m		4.5m		6m		MAX REACH			
	Cf	Cs	Cf	Cs	Cf	Cs	Cf	Cs	Cf	Cs	Distance	
6	kg				*3,200	*3,200			*1,700	*1,700	5.9	
4.5	kg				*3,450	*3,450	*3,350	2,300	*1,650	*1,650	6.8	
3	kg		*5,400	*5,400	*4,150	3,450	*3,600	2,200	*1,600	*1,600	7.3	
1.5	kg		*7,850	5,600	*5,100	3,150	*4,000	2,100	*2,000	1,550	7.4	
ground	kg		*7,800	5,150	*5,750	2,950	*4,300	2,000	*1,950	1,500	7.3	
-1.5	kg	*4,700	*4,700	*8,850	5,050	*5,850	2,850	*4,250	1,950	*2,450	1,650	6.8
-3	kg	*7,900	*7,900	*7,650	5,100	*5,250	2,850		*3,300	2,000	5.9	
-4.5	kg		*5,050	*5,050					*3,100	*3,100	4.4	

Blade Up

B/A (m)	1.5m		3.0m		4.5m		6m		MAX REACH			
	Cf	Cs	Cf	Cs	Cf	Cs	Cf	Cs	Cf	Cs	Distance	
6	kg				*3,200	*3,200			*1,700	*1,700	5.9	
4.5	kg				*3,450	*3,450	*3,350	2,300	*1,650	*1,650	6.8	
3	kg		*5,400	*5,400	*4,150	3,450	*3,600	2,200	*1,600	*1,600	7.3	
1.5	kg		*7,850	5,600	*5,100	3,150	3,550	2,100	*2,000	1,550	7.4	
ground	kg		*7,800	5,150	5,200	2,950	3,400	2,000	*1,950	1,500	7.3	
-1.5	kg	*4,700	*4,700	*8,850	5,050	5,100	2,850	3,350	1,950	*2,450	1,650	6.8
-3	kg	*7,900	*7,900	*7,650	5,100	5,100	2,850		*3,300	2,000	5.9	
-4.5	kg		*5,050	*5,050					*3,100	*3,100	4.4	

Lifting capacity at the arm end without bucket.
For lifting capacity including bucket, weight of the bucket or the bucket with quick coupler must be deducted from the lifting capacities.
Lifting capacities are based on the machine standing on a firm, uniform supporting surface.



Rating over-front (Cf)



Rating over-side (Cs)

- Do not attempt to lift or hold any load that is greater than these rated values at their specified load radius and height. Weight of all accessories must be deducted from the above lifting capacities.
- The rated loads are in compliance with ISO 10567 Hydraulic Excavator Lift Capacity Rating Standard. They do not exceed 87% of hydraulic lifting capacity or 75% tipping load.
- Ratings at bucket lift hook.
- Lifting capacities are based on machine standing on level, firm and uniform ground.
- *Indicates the load is limited by hydraulic capacity rather than tipping capacity.
- Operator should be fully acquainted with the Operator's and Maintenance Instructions before operating this machine and rules for the safe operation of equipment should be adhered to at all times.

LIFTING CAPACITY (METRIC)

913FCR with 700 mm Shoes, 4,600 mm Boom, 2,900 mm Arm

Conditions

Boom length: 4,600 mm
Arm length: 2,900 mm
Bucket: None
counterweight: 3,000 kg
Shoes: 700 mm triple grouser shoes
Blade: YES

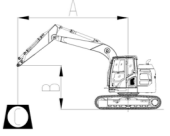

A: load radius
B: load point height
C: Lifting capacity rating
Cf: Rated loads over front
Cs: Rated loads over side

Blade Down

B/A (m)	1.5m		3.0m		4.5m		6m		MAX REACH			
	Cf	Cs	Cf	Cs	Cf	Cs	Cf	Cs	Cf	Cs	Distance	
6	kg				*3,200	*3,200			*1,700	*1,700	5.9	
4.5	kg				*3,450	*3,450	*3,350	2,350	*1,650	*1,650	6.8	
3	kg		*5,400	*5,400	*4,150	3,500	*3,600	2,250	*1,600	*1,600	7.3	
1.5	kg		*7,850	5,700	*5,100	3,200	*4,000	2,150	*2,000	1,550	7.4	
ground	kg		*7,800	5,250	*5,750	3,000	*4,300	2,050	*1,950	1,550	7.3	
-1.5	kg	*4,700	*4,700	*8,850	5,150	*5,850	2,900	*4,250	2,000	*2,450	1,700	6.8
-3	kg	*7,900	*7,900	*7,650	5,200	*5,250	2,900		*3,300	2,050	5.9	
-4.5	kg		*5,050	*5,050					*3,100	*3,100	4.4	

Blade Up

B/A (m)	1.5m		3.0m		4.5m		6m		MAX REACH			
	Cf	Cs	Cf	Cs	Cf	Cs	Cf	Cs	Cf	Cs	Distance	
6	kg				*3,200	*3,200			*1,700	*1,700	5.9	
4.5	kg				*3,450	*3,450	*3,350	2,350	*1,650	*1,650	6.8	
3	kg		*5,400	*5,400	*4,150	3,500	*3,600	2,250	*1,600	*1,600	7.3	
1.5	kg		*7,850	5,700	*5,100	3,200	3,600	2,150	*2,000	1,550	7.4	
ground	kg		*7,800	5,250	5,300	3,000	3,500	2,050	*1,950	1,550	7.3	
-1.5	kg	*4,700	*4,700	*8,850	5,150	5,200	2,900	3,400	2,000	*2,450	1,700	6.8
-3	kg	*7,900	*7,900	*7,650	5,200	5,200	2,900		*3,300	2,050	5.9	
-4.5	kg		*5,050	*5,050					*3,100	*3,100	4.4	



Lifting capacity at the arm end without bucket. For lifting capacity including bucket, weight of the bucket or the bucket with quick coupler must be deducted from the lifting capacities.

Lifting capacities are based on the machine standing on a firm, uniform supporting surface.



Rating over-front (Cf)



Rating over-side (Cs)

- Do not attempt to lift or hold any load that is greater than these rated values at their specified load radius and height. Weight of all accessories must be deducted from the above lifting capacities.
- The rated loads are in compliance with ISO 10567 Hydraulic Excavator Lift Capacity Rating Standard. They do not exceed 87% of hydraulic lifting capacity or 75% tipping load.
- Ratings at bucket lift hook.
- Lifting capacities are based on machine standing on level, firm and uniform ground.
- *Indicates the load is limited by hydraulic capacity rather than tipping capacity.
- Operator should be fully acquainted with the Operator's and Maintenance Instructions before operating this machine and rules for the safe operation of equipment should be adhered to at all times.

LIFTING CAPACITY (METRIC)

913FCR with 600 mm Shoes, 4,600 mm Boom, 2,900 mm Arm

Conditions

Boom length: 4,600 mm
 Arm length: 2,900 mm
 Bucket: None
 Counterweight: 3,000 kg
 Shoes: 500 mm rubber track shoes
 Blade: YES

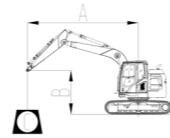

A: load radius
 B: load point height
 C: Lifting capacity rating
 Cf: Rated loads over front
 Cs: Rated loads over side

Blade Down

B/A (m)	1.5m		3.0m		4.5m		6m		MAX REACH		Distance	
	Cf	Cs	Cf	Cs	Cf	Cs	Cf	Cs	Cf	Cs		
6	kg				*3,200	*3,200			*1,700	*1,700	5.9	
4.5	kg				*3,450	*3,450	*3,350	2,250	*1,650	*1,650	6.8	
3	kg		*5,400	*5,400	*4,150	3,350	*3,600	2,150	*1,600	1,550	7.3	
1.5	kg		*7,850	5,500	*5,100	3,100	*4,000	2,050	*2,000	1,500	7.4	
ground	kg		*7,800	5,050	*5,750	2,850	*4,300	1,950	*1,950	1,500	7.3	
-1.5	kg	*4,700	*4,700	*8,850	4,900	*5,850	2,750	*4,250	1,900	*2,450	1,600	6.8
-3	kg	*7,900	*7,900	*7,650	5,000	*5,250	2,750		*3,300	1,950	5.9	
-4.5	kg		*5,050	*5,050					*3,100	3,050	4.4	

Blade Up

B/A (m)	1.5m		3.0m		4.5m		6m		MAX REACH		Distance	
	Cf	Cs	Cf	Cs	Cf	Cs	Cf	Cs	Cf	Cs		
6	kg				*3,200	*3,200			*1,700	*1,700	5.9	
4.5	kg				*3,450	*3,450	*3,350	2,250	*1,650	*1,650	6.8	
3	kg		*5,400	*5,400	*4,150	3,350	3,600	2,150	*1,600	1,550	7.3	
1.5	kg		*7,850	5,500	*5,100	3,100	3,450	2,050	*2,000	1,500	7.4	
ground	kg		*7,800	5,050	5,100	2,850	3,350	1,950	*1,950	1,500	7.3	
-1.5	kg	*4,700	*4,700	*8,850	4,900	5,000	2,750	3,300	1,900	*2,450	1,600	6.8
-3	kg	*7,900	*7,900	*7,650	5,000	5,000	2,750		*3,300	1,950	5.9	
-4.5	kg		*5,050	*5,050					*3,100	3,050	4.4	

STANDARD EQUIPMENT

ENGINE SYSTEM

- Cummins F3.8 engine, EU Stage II, turbo charged, 4 cylinder, 4 stroke, water cooled
- 3-power modes (Power, Standard, Economy)
- Engine overheat prevention system
- Engine oil low pressure protection
- Auto-idle speed control
- Automatic engine shutdown
- Twin-core air filter with integrated pre-filter
- Plastic fuel tank
- Manual fuel lifting pump
- Fuel pre-filter with water separator and water detection
- Remote engine oil filter
- Ground level engine oil gauge
- Lockable engine oil gauge
- Radiator dust-proof net
- Air conditioner compressor belt automatic tense
- 20°C cold start capability

HYDRAULIC SYSTEM

- Full electric control hydraulic system
- Power boost function
- Pilot control shut-off lever
- Pilot accumulator
- Automatic swing parking brake
- Swing with anti-reverse function
- Automatic two-speed travel
- Automatic travel parking brake

OPERATOR STATION

- Pressurized and sealed cab
- ROPS certified cab
- Lower windshield can be removable
- Openable front windshield with assist device
- Large roof window with slide sliding sun visor
- Air suspension deluxe seat (with heater and head rest) +retractable seat belt (75 mm width, red colour, with green alarm lamp)

- Consoles and seat height adjustable follow-up
- 8 inches high resolution LCD touch screen + integrated control panel
- Automatic air conditioner, heater, defroster
- Fire extinguisher
- Safety hammer for cab evacuation
- Green safety glass
- Cab interior lighting
- Left armrest box can be reversed

ELECTRICAL SYSTEM

- Monitor: working mode, working hour, water temperature, oil temperature, fuel level, DEF level, fuel consumption, rear vision, fault code, work condition etc. machine information.
- Warn: low engine oil pressure, low fuel level, air filter clog, machine overheat, low coolant level, low DEF level, maintenance remind etc.
- Two maintenance free battery
- Battery disconnect switch
- Front window wiper with time adjustable intermittent feature
- AM/FM radio with auxiliary input
- Blue tooth
- Working lights close time delay by programmable
- Cab interior decoration lights close time delay by programmable
- Ground level engine shutoff switch
- Left boom working light
- Right platform working light
- Rear and right side view cameras
- Set password for auxiliary hydraulic-flow adjustments
- Work tool flow and pressure programmable memories
- Control pattern-change valve

UNDERCARRIAGE

- Standard track undercover
- 500mm track-shoes with triple grousers
- Rollers, bottom - 7 each side
- Rollers, top - 1 each side
- 1 piece track guards (each side)
- Travel motor guards
- Centralized lubrication for swing bearing
- Towing eye on base frame
- Traction hole on base frame
- 600 mm track-shoes with triple grousers

UPPER STRUCTURE

- Punched metal anti-slip plates
- Foot pedal is in engine room
- Tool box
- Standard frame undercover
- One key for all locks
- 3,000 kg counterweight

DIGGING EQUIPMENT

- 4,600 mm boom
- 2,500 mm arm
- Arm front end with guard bars
- Manual centralized lubrication on boom
- 0.5 m³ standard bucket

SERVICE & MAINTENANCE

- Maintenance tool kit
- Maintenance parts package
- Data diagnostic port
- Self-diagnostic system

OPTIONAL EQUIPMENT

ENGINE SYSTEM

- Electric refueling pump with auto shutoff

HYDRAULIC SYSTEM

- Boom and arm holding valves
- Hand proportional control auxiliary dual way pipes
- Hand proportional control auxiliary swing pipes
- PTO max flow with manual control
- Auxiliary single-double hydraulic lines exchange on the monitor
- Auxiliary dual pipe flow & pressure adjustable
- High pressure quick-coupler pipes
- Attachment oil drain line
- Bucket cylinder rod protect

OPERATOR STATION

- Cab lower window guard
- Cab top guard
- Openable cab front guard
- Cab front guard and top guard (falling object protective structure)
- Sunscreen
- Front window rain visor

ELECTRICAL SYSTEM

- Overload warning device
- Travel alarm
- Rotating beacon
- Rotating warning light
- Reserved installation seat and wiring harness for double warning lights in the cab
- Quicker-coupler opening warning
- Starting code
- Right boom working light
- 360° view
- Cab LED ceiling lights (2 in front)
- Cab LED ceiling lights (4 in front and 2 in rear)
- Reserved installation seat and wiring harness for the long strip cab LED ceiling lights
- 12V power supply

UNDERCARRIAGE

- Reinforced track undercover
- 700 mm track-shoes with triple grousers and auxiliary track footrest
- 500 mm rubber block track
- Dozer with locking function

UPPER STRUCTURE

- Guard fence of upper frame around
- Reinforced frame undercover
- 500 kg extra counterweight

DIGGING EQUIPMENT

- Bucket linkage with lifting eye
- Bucket lifting hole
- 2,100 mm short reach arm
- 2,900 mm long reach arm
- Bucket thumbs



Guangxi LiuGong Machinery Co., Ltd.
No. 1 Liutai Road, Liuzhou, Guangxi 545007, PR China
T: +86 772 388 6124 E: overseas@liugong.com
www.liugong.com

Like and follow us:



LG-PB-EU-913FCR-18-012022-ENG

The LiuGong series of logos herein, including but not limited to word marks, device marks, letter of alphabet marks and combination marks, as the registered trademarks of Guangxi LiuGong Group Co., Ltd. are used by Guangxi LiuGong Machinery Co., Ltd. with legal permission, and shall not be used without permission. Specifications and designs are subject to change without notice. Illustrations and pictures may include optional equipment and may not include all standard equipment. Equipment and options varies by regional availability.